

FILTER OVERVIEW WITH SERVICE INTERVALS AND CAPACITIES

9750 STS Series Canadian Combine

ENGINE AIR FILTER

SECONDARY AIR FILTER – [AH174196](#)

Change secondary filter only with primary filter.

ENGINE AIR FILTER

PRIMARY AIR FILTER – [AH170798](#)

Replace every 400 hours or
Service filters only when engine air filter light stays ON or
change as required.

Note: Replace Secondary Filter with Primary Filter.

CAB AIR FILTER

RECIRCULATION AIR FILTER – [AH115836](#)

Clean or replace every 200 hours and as
required.

CAB AIR FILTER

AIR FILTER, HEAVY DUTY – [AH168783](#)

AIR FILTER, STANDARD – [AH115833](#)

Clean or replace every 50 hours
and as required.

HYDROSTATIC PUMP / ENGINE GEARCASE / HYDRAULIC FILTER

OIL FILTER – [AH128449](#)

Replace every 400 hours.

Note: Replace all three filters at a time.

ENGINE OIL FILTER

OIL FILTER – [RE58935](#)

Replace every 200 hours.

Note: Change oil every 100 hours if fuel
contain more than 0.5% sulfur.

Change oil every 250 hours when using
TORQ-GARD SUPREME® PLUS-5W™.

ENGINE FUEL FILTER

FUEL FILTER – [RE507284](#)

Replace every 500 hours.

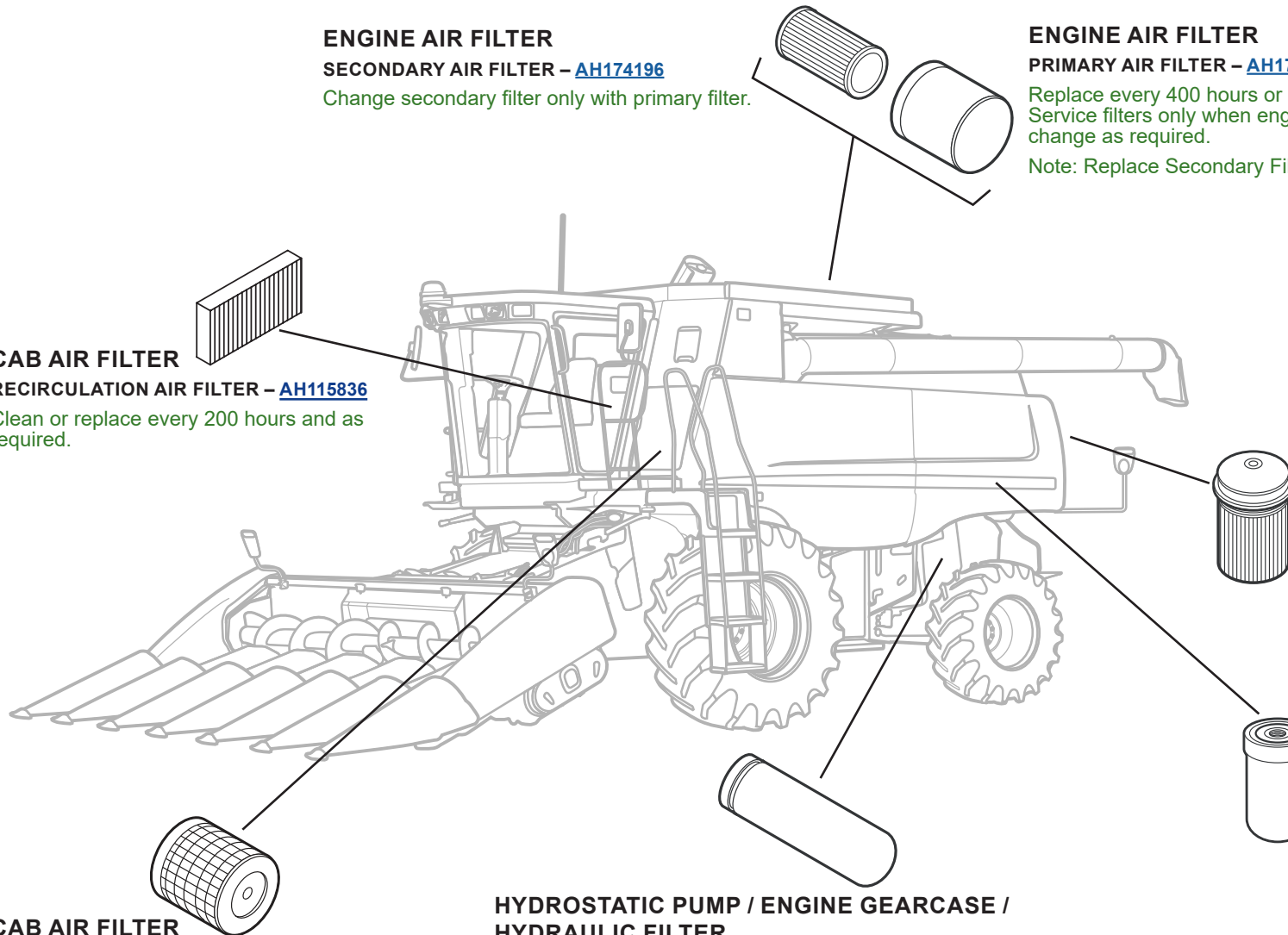

JOHN DEERE
Genuine Parts and Service

(Click here for [capacity](#))

CAPACITIES

9750 STS Series Canadian Combine

CAPACITIES (Approximate):

Fuel Tank:

..... 945 L (249.64 gal)

Cooling System With Heater:

..... 55 L (14.52 gal)

Hydraulic / Hydrostatic Reservoir:

..... 34 L (8.98 gal)

Feeder House Reverser Gearcase:

Standard 0.9 L (0.23 gal)

High Capacity With Cooler 3.5 L (0.92 gal)

Final Drives (Each):

Single Reduction 8.5 L (2.24 gal)

Countershaft Drive Gearcase:

..... 1.2 L (0.31 gal)

Loading Auger Gearcase:

..... 3.8 L (1 gal)

Engine Gearcase With Transfer:

..... 21.3 L (5.62 gal)

Engine Crankcase With Filter:

..... 42 L (11.09 gal)

Transmission:

..... 9.6 L (2.53 gal)

Two Speed Separator Drive Gearcase:

..... 4.7 L (1.24 gal)

[Return to Filter Overview](#)